

# Service Manual

## Telephone Equipment

### KX-TCD953RUB

Digital Cordless Phone

(for Russia)

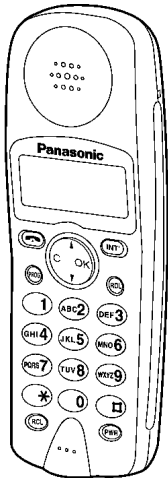

(HANDSET)



(BASE UNIT)

#### SPECIFICATION

Standard:	DECT=Digital Enhanced Cordless Telecommunications GAP=Generic Access Profile (herstellerübergreifendes DECT-Funkübertragungsverfahren)	Battery life, Handset (if batteries are fully charged): Operating conditions:	Stand-by: Up to 65 hours (Ni-Cd) Talk: Up to 6 hours (Ni-Cd) 5° - 40°C, 20 - 80% relative air humidity (not condensing)
Number of channels:	120 Duplex Channels	Dialing modes:	Pulse/Tone
Frequency range:	1.88 GHz to 1.9 GHz	Recall button (set default): for PBX:	Flash (80 ms) Flash (700 ms)
Duplex procedure:	Time Multiplex, 10 ms frame length	Recall button (option):	Earth (400 ms/1300 ms)
Channel Spacing:	1728 kHz	Dimensions, Base unit:	approx 201 mm x 171 mm x 73 mm (L x W x D)
Bit rate spacing:	1152 kbit/s	Dimensions, Handset:	approx 160 mm x 56 mm x 32 mm (L x W x D)
Modulation:	GFSK	Weight, Base unit:	approx 460 g
Voice coding:	32 kbit/s	Weight, Handset:	approx 150 g
Operation range:	Up to 300 m outdoors, up to 50 m indoors	Telephone line cord length:	approx 2.1 m
Analog telephone connection:	Telephone Line / PBX	AC adaptor cord length:	approx 2 m
Power source:	AC Adaptor 230 V ~ /50 Hz	Connection jack:	
Power consumption, Base unit:	5 VA	AC adaptor cord:	Modular jack 6/4
		AC adaptor plug:	Euro Jack

Design and specification are subject to change without notice.

# 20 SCHEMATIC DIAGRAM (BASE UNIT)

## 20.1. Line Interface

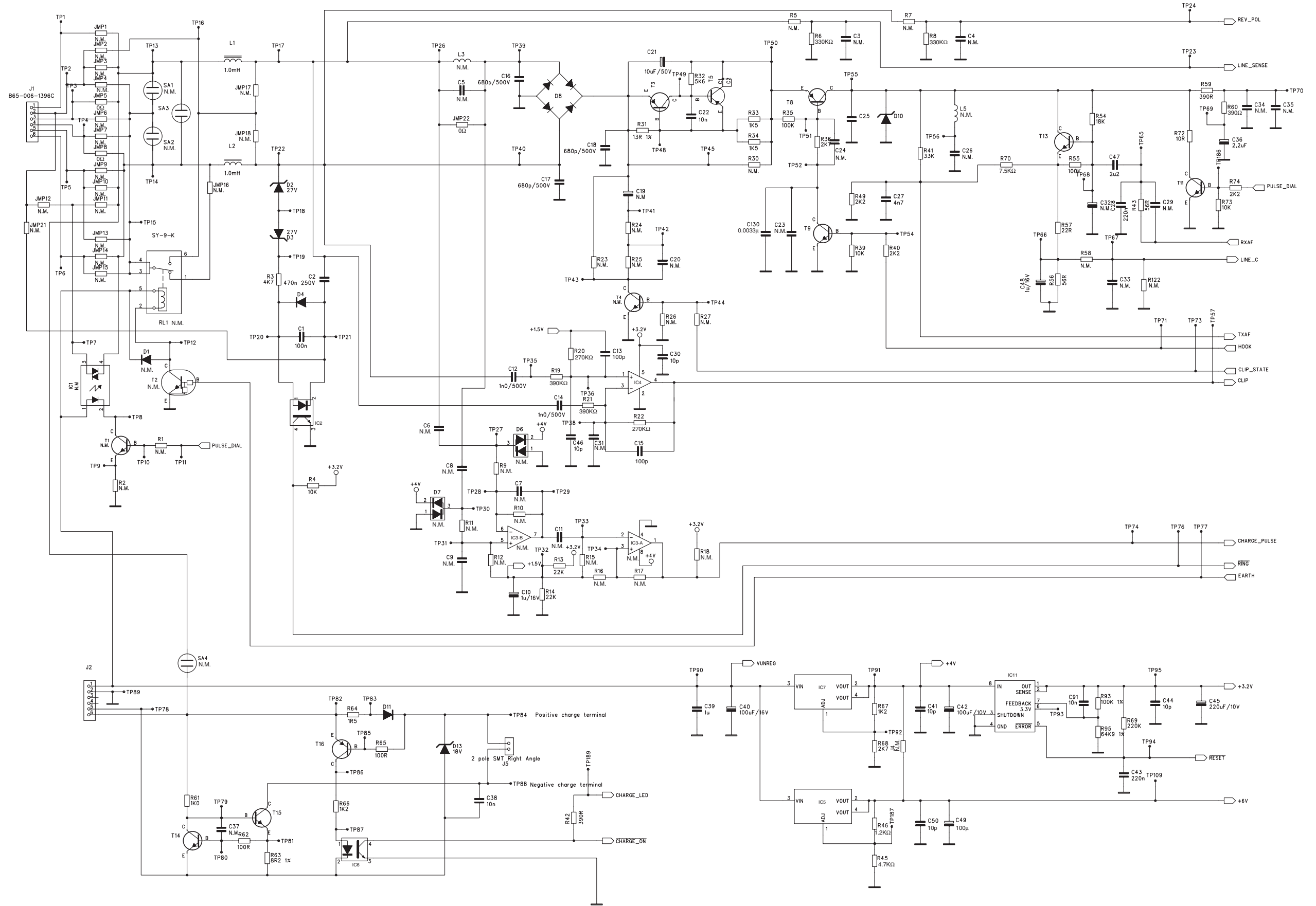

# 20.2. Baseband and RF

