

CTF-70C

SERVICE BOOK

CTF-70C BOM LIST

Designators	Comment	Footprint
B	BELL	BELL
C101	104	0603
C102	104	0603
C103	104	0603
C104	104	0603
C105	104	0603
C201	104	0603
C202	104	0603
C203	33P	0603
C204	33P	0603
C205	104	0603
C206	104	0603
C207	104	0603
C208	104	0603
C209	104	0603
C401	105	0805
C402	104	0603
C403	105	0805
C404	104	0603
C405	104	0603
C406	104	0603
C407	104	0603
C408	104	0603
C409	104	0603
C410	104	0603
C411	104	0603
CN101	PH-10AW	PH-10AW
CN102	PH-11AW	PH-11AW
CN103	FFC 0.5mm, 40Pin	40PIN
CN104	FFC 0.5mm, 40Pin	40PIN
CN105	85202-1002	10PIN
CN106	4PIN	PH-4AW
CN201	LAMP SW	2PIN
D101	1N5825	1N5819
D102	1N4007	1N5819
D103	1N4007	1N5819
D201	MAZS033	D1
D202	MA159A	D2
D203	MA159A	D2
D204	MA159A	D2
D205	1N4148	MLL34
D401	MA3100-M	SOT-23
D402	MAZS0750L	D1
D403	MAZS0910L	D1
E101	470u/25V	10X10.5
E102	470u/25V	10X10.5
E103	470u/25V	10X10.5
E104	220u/16V	6.3X8
E105	100u/16V	6.3X5.5
E201	100u/16V	6.3X5.5
E202	100u/16V	6.3X5.5

Designators	Comment	Footprint
E401	470u/25V	10X10.5
E402	470u/25V	10X10.5
E403	470u/25V	10X10.5
F101	000	1206
F102	000	1206
F103	000	1206
F104	000	1206
F105	NC	1206
K201	SK-12D01-EG5	SK-12D01-EG5
L101	47uH	D124C
L102	47uH	D124C
L103	47uH	D124C
L--ONLY	12V/5W	LAMPKZ
R101	5K6	0603
R102	1K	0603
R103	10K	0603
R104	1K	0805
R105	10K	0603
R106	1K	0805
R201	2R2	1206
R202	2R2	1206
R203	1K	0603
R204	1K	0603
R205	10K	0603
R206	1M	0603
R207	47R	0603
R208	10K	0603
R209	10K	0603
R210	22K	0603
R211	68K	0603
R212	22K	0603
R213	68K	0603
R214	1K	0603
R215	1K	0603
R216	1K	0603
R217	1K	0603
R218	1K	0603
R219	10K	0603
R220	10K	0603
R221	10K	0603
R222	10K	0603
R223	10K	0603
R224	10K	0603
R401	470	1206
R402	2R2	1206
R403	2R2	1206
R404	2R2	1206
R405	2R2	1206
R406	470	0603
R407	6R2	1206
R408	6R2	1206

CTF-70C BOM LIST		
Designators	Comment	Footprint
R409	6R2	1206
R410	6R2	1206
R411	6R2	1206
R412	6R2	1206
R413	6R2	1206
R414	6R2	1206
R415	6R2	1206
R416	6R2	1206
R417	6R2	1206
R418	6R2	1206
R419	180	0603
R420	3R6	1206
R421	3R6	1206
R422	3R6	1206
R423	3R6	1206
R424	3R6	1206
R425	3R6	1206
RA201	100R	R4
RA202	1K	R4
RA203	1K	R4
RA204	10K	R4
RA205	10K	R4
RA206	10K	R4
RA207	10K	R4
RA208	10K	R4
RA209	10K	R4
RA210	10K	R4
RA211	1K	R4
R--ONLY	12V/5W	LAMPKZ
U101	PQ1CY1032Z	T0-263
U102	PQ09DZ11	SC-63
U201	78L05	SOT-89
U202	M38B59	QFP80
U203	24C02	S0-8
U401	FMC3A	SOT-25
U402	BA6285FP	SOP24P
U403	BA6285FP	SOP24P
U404	BA6285FP	SOP24P
V101	2SB1188	SOT-89
V102	DTC143TKA	SOT-23
V103	2SA1952	SOT-252
V104	2N5551	SOT-23
V201	2N5401	SOT-23
V203	2N5551	SOT-23
V204	2N5551	SOT-23
V401	C3518	SOT-252
V402	C3518	SOT-252
V403	C3518	SOT-252
V404	C3518	SOT-252
V405	2N5551	SOT-23
V406	2N5551	SOT-23

CTF-70C BOM LIST		
Designators	Comment	Footprint
X201	4.19MHz	HC-49S
CTF-70C BOM LIST		
Designators	Comment	Footprint
C11	1u	0805
C12	1u	0805
C13	222	0603
C14	222	0603
C15	104	0603
C16	104	0603
C17	104	0603
C18	104	0603
C19	102	0603
C20	102	0603
C21	103	0603
C22	103	0603
C23	103	0603
C24	103	0603
C25	102	0603
C26	102	0603
C27	104	0603
C28	104	0603
C29	104	0603
C30	104	0603
C31	102	0603
C32	104	0603
C33	104	0603
CN11	85202-1002	10PIN
D11	RT5-2337	IR
D12	RT5-2337	IR
D13	RT5-2337	IR
D14	RT5-2337	IR
D15	RT5-2337	IR
D16	RT5-2337	IR
D17	RT5-2337	IR
D18	RT5-2337	IR
D19	Red-LED	IR
E11	10u/50V	5X11
E12	10u/50V	5X11
E13	10u/50V	5X11
E14	100u/16V	5X11
E15	10u/50V	5X11
E16	33uF/16V	5X11
E17	100u/16V	5X11
E18	220u/10V	5X11
E19	470u/16V	8X11.5
E20	100u/16V	5X11
FOUNC	SWPT	TP1138D
K5	SPVG	SPVG
R11	561	0603
R12	561	0603

CTF-70C BOM LIST		
Designators	Comment	Footprint
C316	103	0603
C317	474	0603
C318	105	0805
C319	105	0805
C320	100u/16V	6*5
C321	105	0805
C322	105	0805
C323	821	0603
C324	105	0805
C325	105	0805
C326	105	0805
C327	105	0805
C328	6.3V/220uF	7343
C329	104	0603
C330	682	0603
C331	335	1206
C342	105	0805
C343	105	0805
C344	105	0805
C345	103	0603
C351	104	0603
C352	47u/25V	6*5
C353	104	0603
C354	106	1210
C355	106	1210
C356	33P	0603
C41	104	0603
C42	681	0603
C43	OPEN	0603
C44	104	0603
C45	103	0603
C46	104	0603
C501	10u/25V	1210
C502	10u/25V	1210
C503	10u/25V	1210
C504	104	0603
C505	104	0603
C506	104	0603
C507	10u/25V	1210
C508	104	0603
C509	105	0805
C51	221	0603
C52	221	0603
C61	104	0603
C62	106	1210
C63	104	0603
C64	106	1210
C81	100u/16V	6*5
C82	100u/16V	6*5
C83	104	0603
C84	184/100V	RC0.7

CTF-70C BOM LIST		
Designators	Comment	Footprint
C85	22P/3KV	RC0.7
CN1	50PIN	50PIN
CN2	4PIN	4PIN
CN3	10PIN	10PIN
CN4	26PIN	26PIN
CN5	5-3PIN	5-3PIN
D131	BAT54C	SOT-23
D141	BAT54C	SOT-23
D31	100	0603D
D41	MA335	1206
D501	BAT54C	SOT-23
D502	BAT54C	SOT-23
H-POS	*50K	3*3
L101	22uH	1210
L102	100uH	1210
L103	100uH	BC53
L104	22uH	1210
L106	22uH	1210
L107	000	1210
L131	220uH	TS100H2*10
L132	100uH	1210
L141	100uH	1005
L142	100uH	1210
L21	2R2uH	1210
L301	22uH	1210
L81	47uH	1005
Q131	2SA1118	SOT-89
Q141	2SB709A	SOT-23
Q142	2SC4672	SOT-89
Q301	2N5551	SOT-23
Q303	2SB709A	SOT-23
Q51	2N5401	SOT-23
Q81	2N5551	SOT-23
Q82	2N5551	SOT-23
Q83	2N5401	SOT-23
Q84	2SC3815	SOT-252-3
Q85	2SC3518	SOT-252-3
QM51	XN4501	SOP6
R000	000	0603
R001	000	0603
R1	100	0603
R10	000	0603
R11	560	0603
R12	560	0603
R13	560	0603
R131	10K	0603
R132	39K	0603
R133	39K	0603
R134	5K6	0603
R135	56K	0603
R136	18K	0603

CTF-70C BOM LIST		
Designators	Comment	Footpri nt
R137	33K	0603
R138	470	0603
R139	1K	0603
R14	100	0603
R140	68K	0603
R141	4K7	0603
R142	56K	0603
R143	39K	0603
R144	39K	0603
R145	18K	0603
R146	33K	0603
R147	1K	0603
R148	470	0603
R149	5K6	0603
R15	100	0603
R150	1K	0603
R16	100	0603
R161	000	0603
R162	000	0603
R17	100	0603
R18	100	0603
R19	100	0603
R2	100	0603
R21	100	0603
R22	1M	0603
R23	100	0603
R24	100	0603
R242	1M	0603
R243	5K6	0603
R244	10K	0603
R245	5K6	0603
R246	100	0603
R247	100	0603
R248	100	0603
R249	100	0603
R251	47K	0603
R252	47K	0603
R253	47K	0603
R254	47K	0603
R255	47K	0603
R256	47K	0603
R257	47K	0603
R258	47K	0603
R259	200K	0603
R261	47K	0603
R262	47K	0603
R263	47K	0603
R264	47K	0603
R265	47K	0603
R266	47K	0603
R267	47K	0603

CTF-70C BOM LIST		
Designators	Comment	Footpri nt
R268	47K	0603
R269	68K	0603
R27	1K	0603
R28	000	0603
R281	390	0603
R282	390	0603
R283	390	0603
R284	100	0603
R285	100	0603
R286	100	0603
R29	1K	0603
R3	560	0603
R301	10K	0603
R302	10K	0603
R303	39	0603
R304	39	0603
R305	10M	0603
R306	1M	0603
R307	5K6	0603
R308	1K5	0603
R309	330	0603
R31	1K	0603
R310	5K6	0603
R312	2K2	0603
R313	8K2	0603
R314	100	0603
R315	100	0603
R316	100	0603
R317	20K	0603
R318	1K	0603
R319	470K	0603
R32	1K	0603
R320	560	0603
R321	18K	0603
R322	330K	0603
R323	100K	0603
R324	330K	0603
R33	1K	0603
R34	560	0603
R341	10K	0603
R342	10K	0603
R343	10K	0603
R35	560	0603
R351	10K	0603
R352	20K	0603
R353	10K	0603
R354	10K	0603
R355	20K	0603
R356	20K	0603
R357	1K	0603
R358	5K6	0603

CTF-70C BOM LIST		
Designators	Comment	Footprint
R36	100	0603
R37	1K	0603
R38	1K	0603
R4	560	0603
R40	8K2	0603
R41	68K	0603
R42	47K	0603
R43	4K7	0603
R44	4K7	0603
R45	20K	0603
R46	82K	0603
R47	1M	0603
R48	10K	0603
R49	2K2	0603
R5	OPEN	0603
R501	75	0603
R502	75	0603
R503	75	0603
R504	100K	0603
R505	100K	0603
R506	100K	0603
R507	100K	0603
R508	100K	0603
R509	100K	0603
R51	15K	0603
R511	1K	0603
R512	1K	0603
R513	10K	0603
R514	10K	0603
R52	15K	0603
R53	200K	0603
R54	39K	0603
R55	3K	0603
R56	10K	0603
R57	15K	0603
R58	10K	0603
R6	000	0603
R61	560	0603
R62	10K	0603
R63	560	0603
R64	100K	0603
R7	OPEN	0603
R8	100	0603
R81	4K7	0603
R82	4K7	0603
R83	3K3	0805
R84	3K3	0805
R9	100	0603
T 1	1340	TOK01308
T301	637BN-P1040-NK	5CCS
U1	UPS017	QFP48

CTF-70C BOM LIST		
Designators	Comment	Footprint
U101	7805	SOT-252-3
U102	TL1451	S0-16W
U201	MTV021-24	DIP24
U301	IR3Y29B	QFP48
U302	HEF4053	S0-16
U303	NJM3414A	S0-8
U4	NJM2107F	SOT-25
U501	HEF4053	S0-16
U8	HEF4053	S0-16
VCDC	*50K	3*3
VCO	VR103	3*3
VR301	*50K	3*3
VR302	*50K	3*3
VR303	*50K	3*3
X301	4.43MHz	HC-49S
X302	3.57MHz	HC-49S
CTF-70C BOM LIST		
Designators	Comment	Footprint
C101	105	1210
CN101	10HEADER	10P
D101	BLUE	LED2
D102	BLUE	LED2
D103	BLUE	LED2
D104	BLUE	LED2
D105	GREEN	LED2
D106	GREEN	LED2
D107	GREEN	LED2
D108	GREEN	LED2
D109	GREEN	LED2
D110	GREEN	LED2
DOWN	SWITCH	PB1
LEFT	SWITCH	PB1
ON/OPEN	SWITCH	PB1
R101	1K	0603
R102	1K5	0603
R103	2K	0603
R104	2K7	0603
R105	2K2	0603
R106	220	0603
R107	2K2	0603
R108	220	0603
R109	2K2	0603
R110	220	0603
R111	470	0805
R112	470	0805
R113	220	0603
RIGHT	SWITCH	PB1
UP	SWITCH	PB1
V101	2N5551	SOT-23
V102	2N5551	SOT-23
V103	2N5551	SOT-23

RFM769_301 PCB LAYOUT

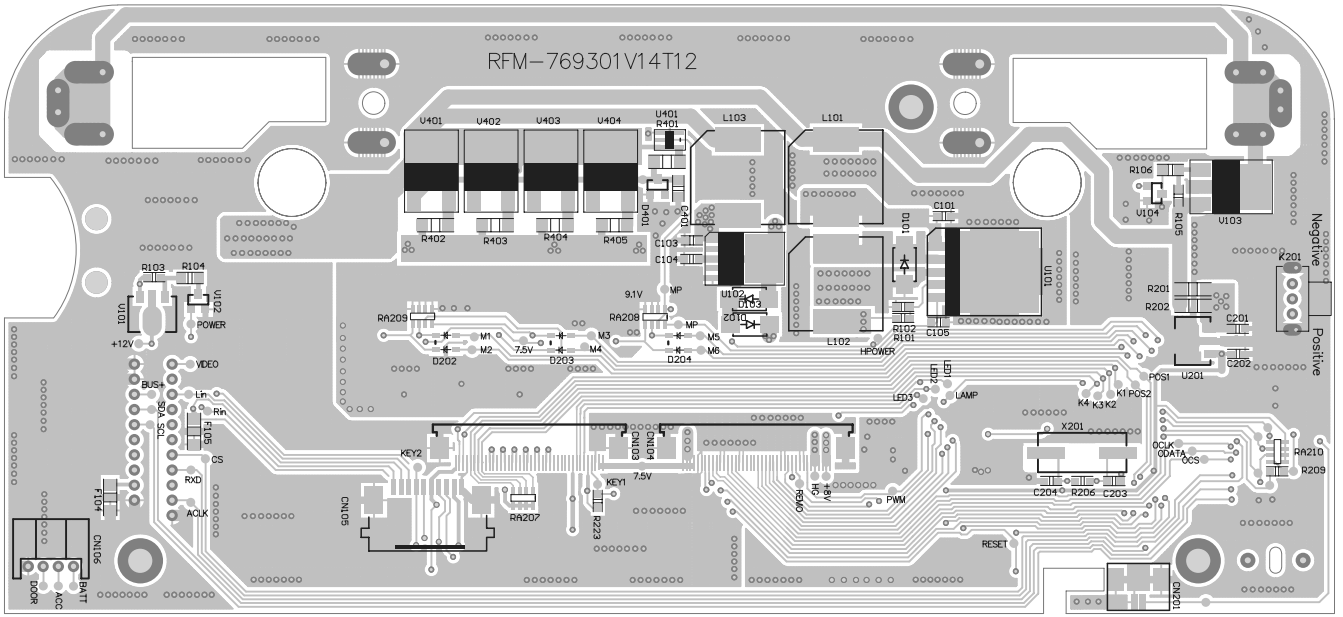

RFM769_302 PCB LAYOUT

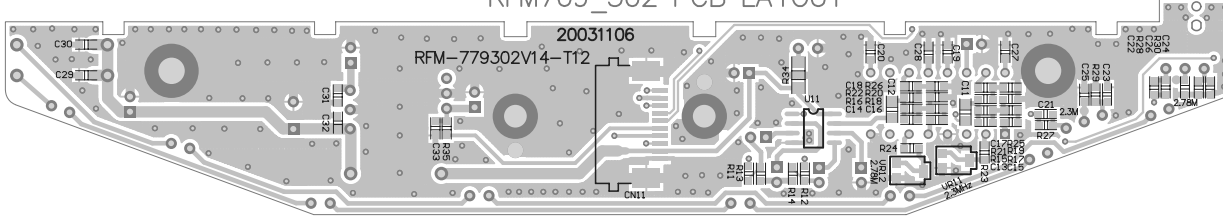

RFM769_303 PCB LAYOUT

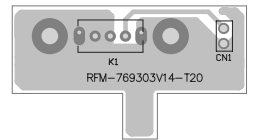

RFM769_304 PCB LAYOUT

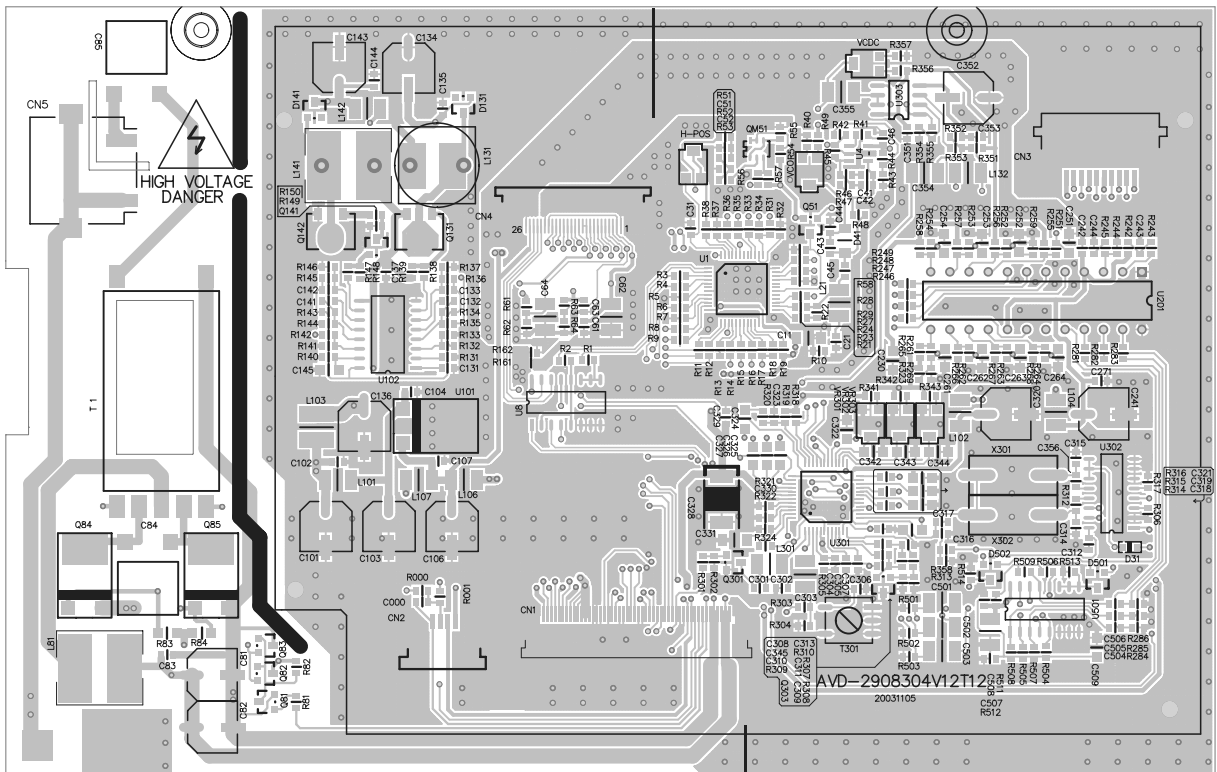

RFM769_305 PCB LAYOUT

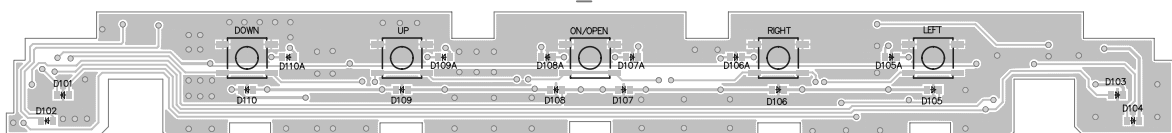

RFM769_301 PCB LAYOUT

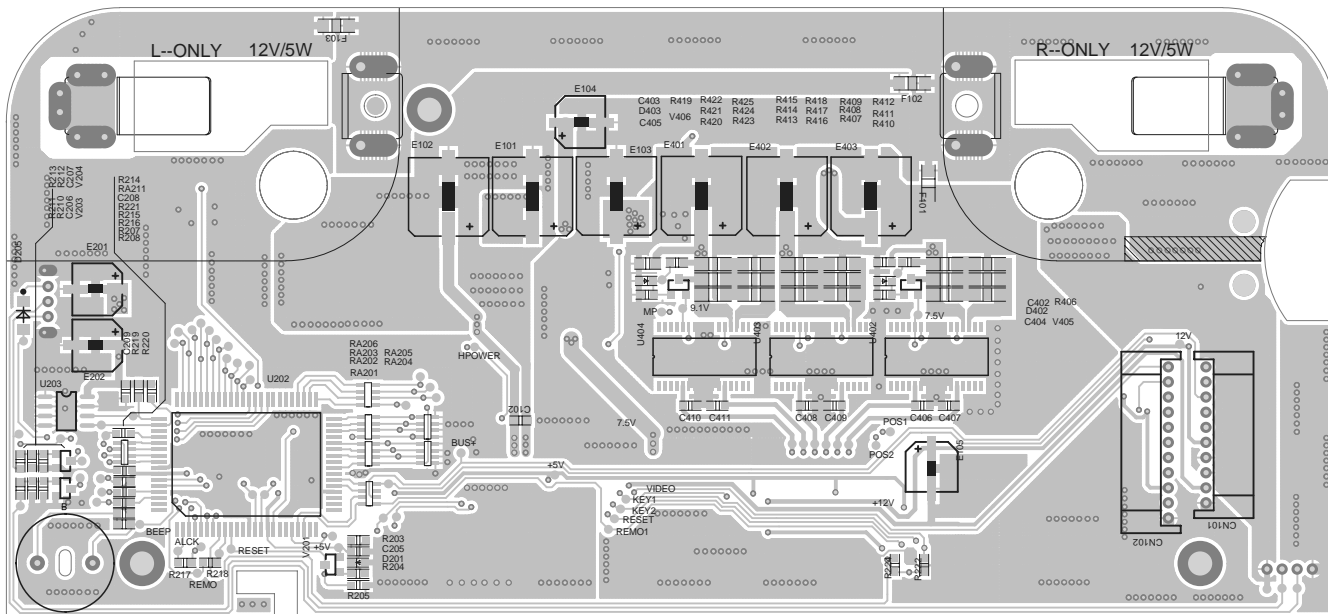

RFM769_303 PCB LAYOUT

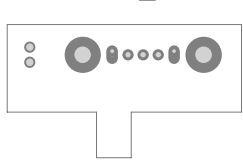

RFM769_302 PCB LAYOUT

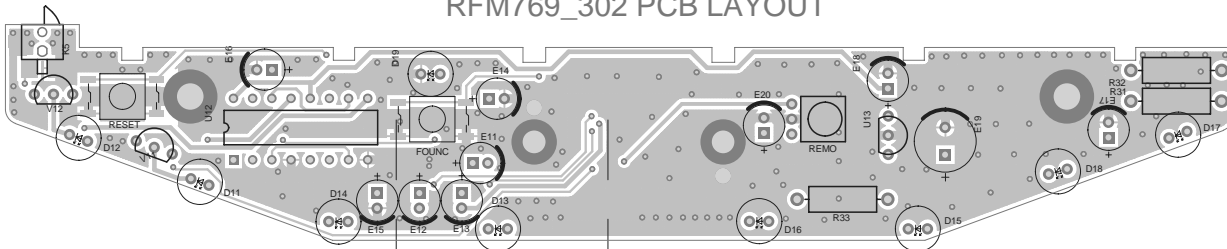

RFM769_304 PCB LAYOUT

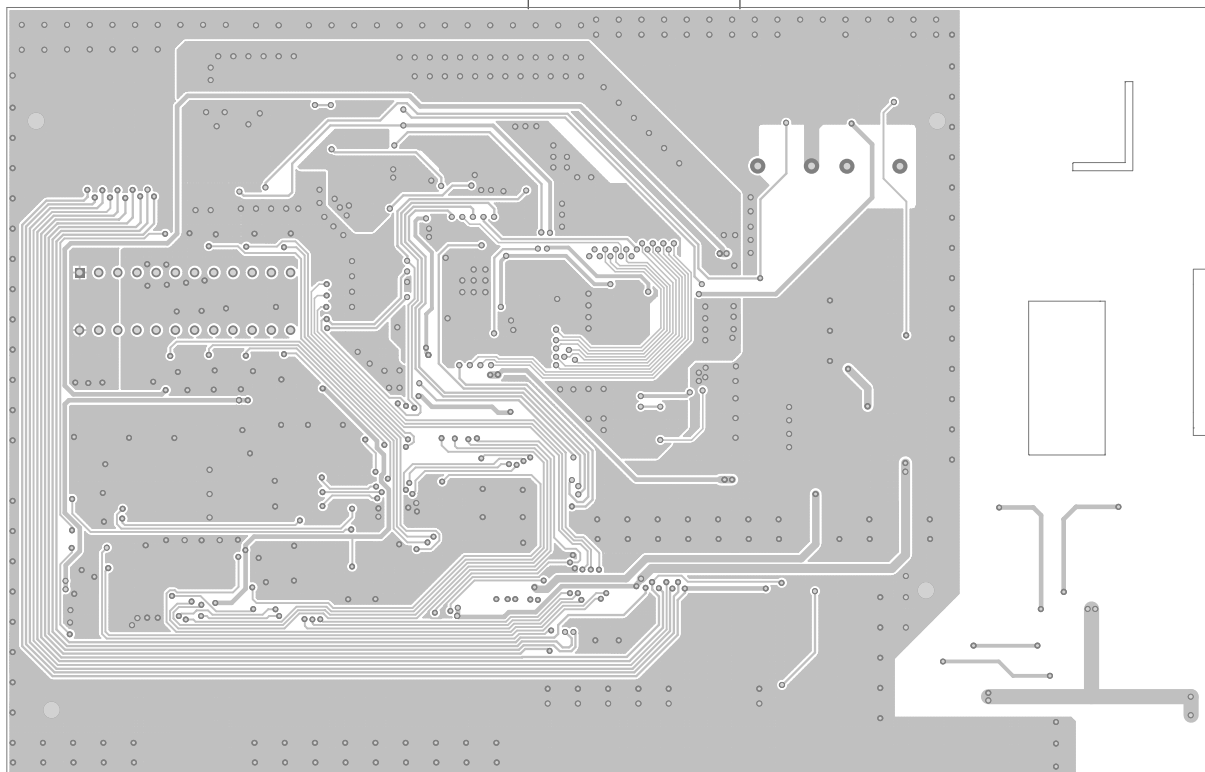

RFM769_305 PCB LAYOUT

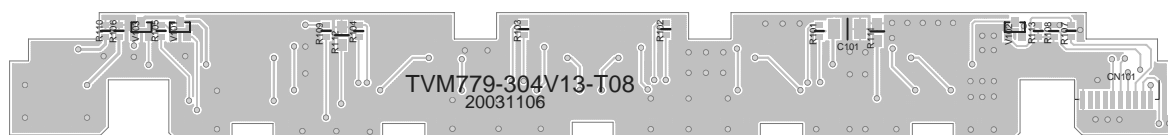

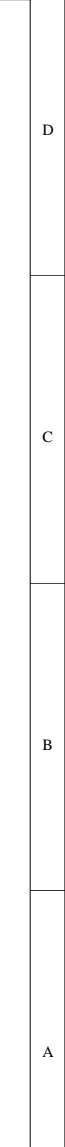
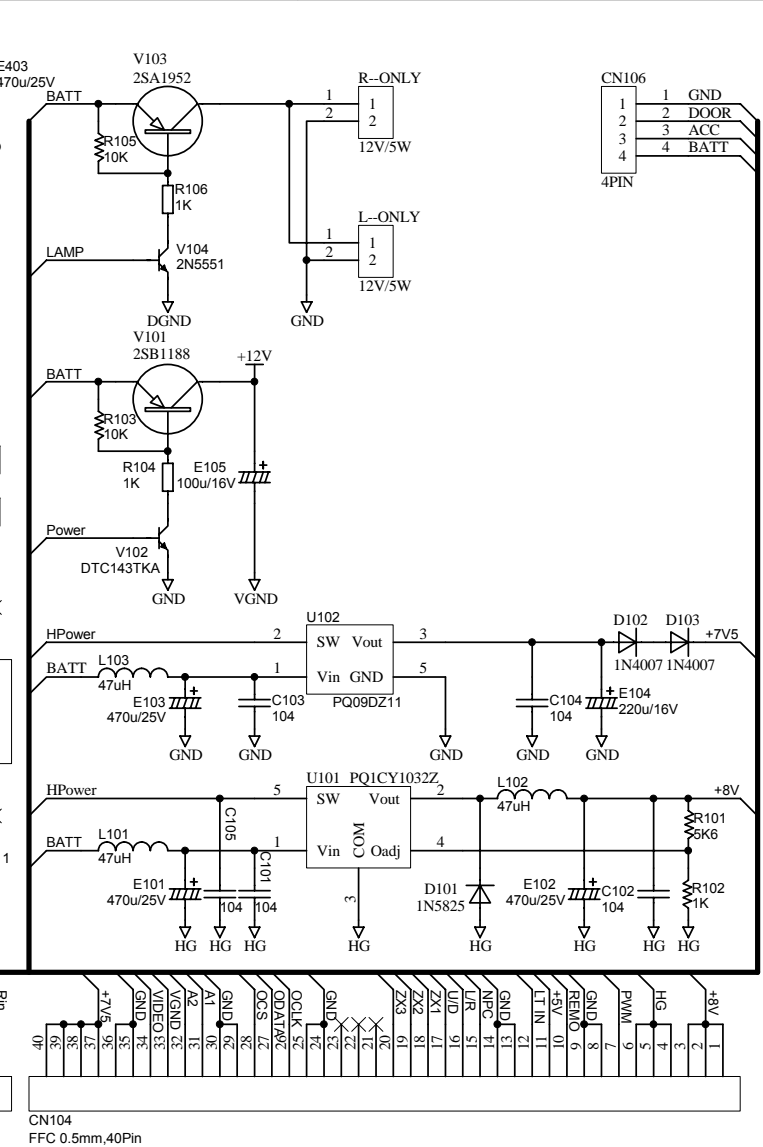
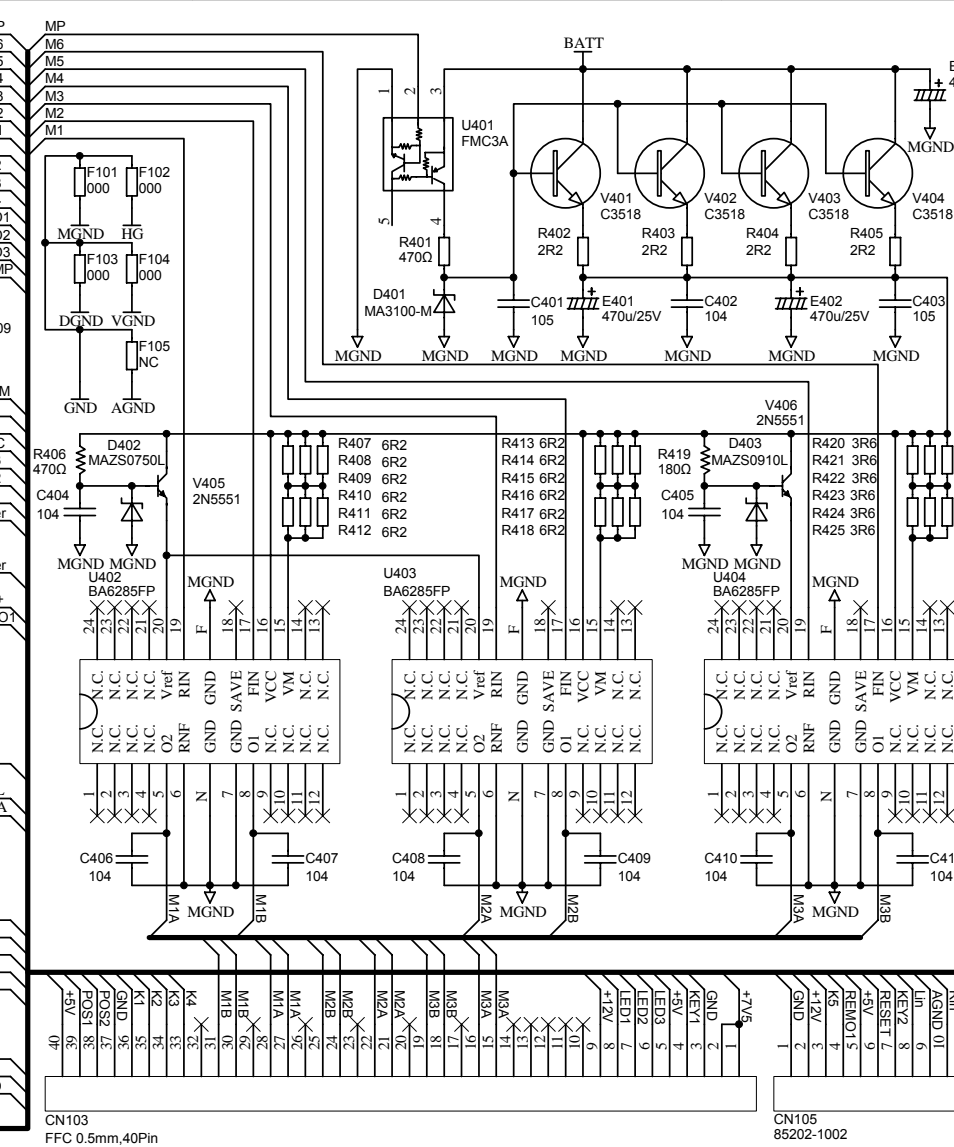
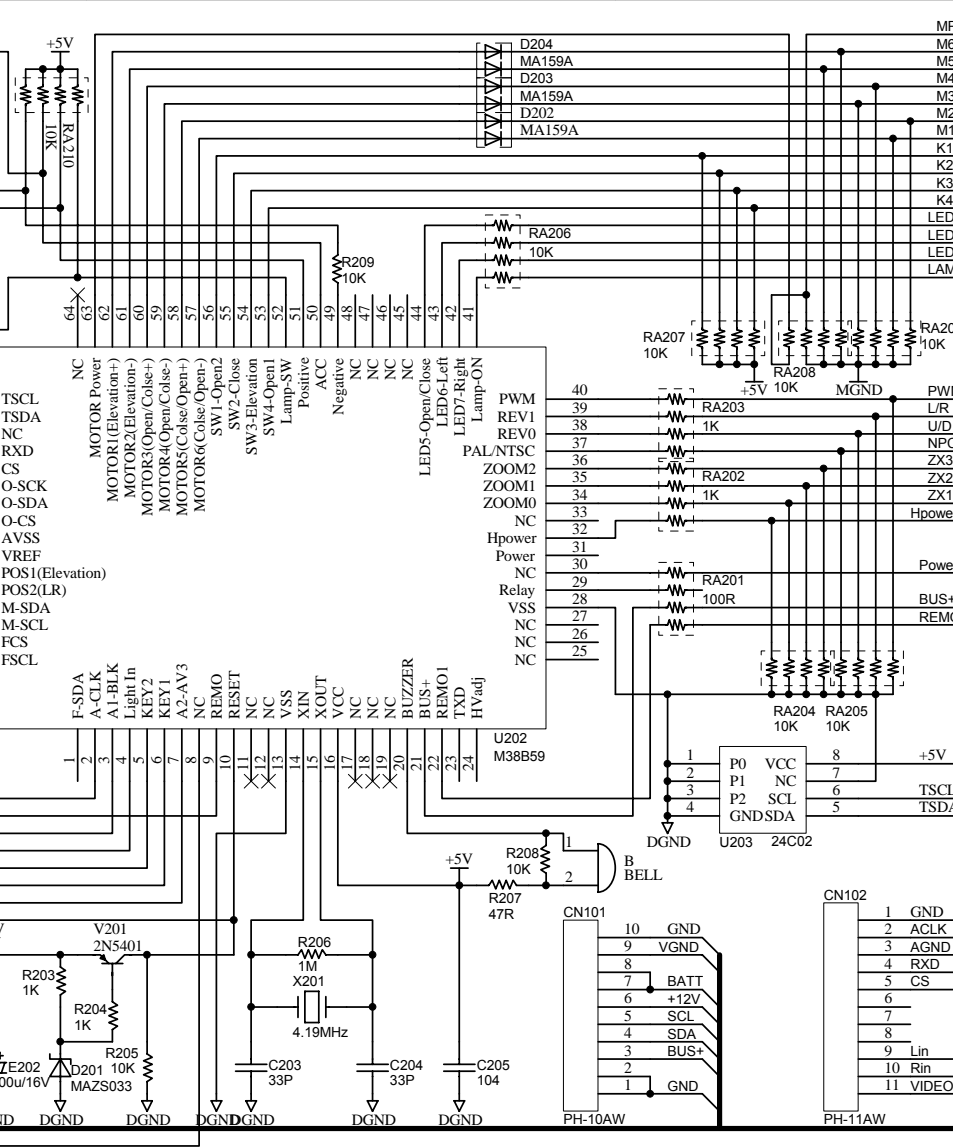
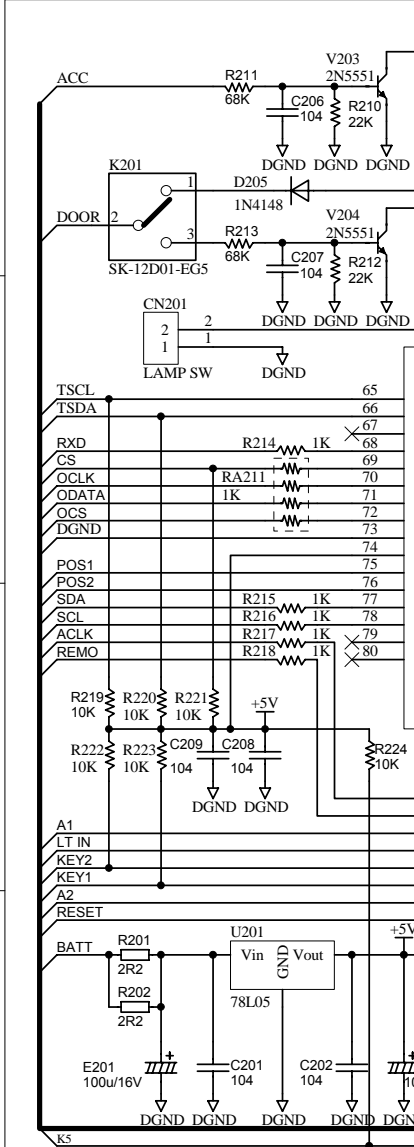
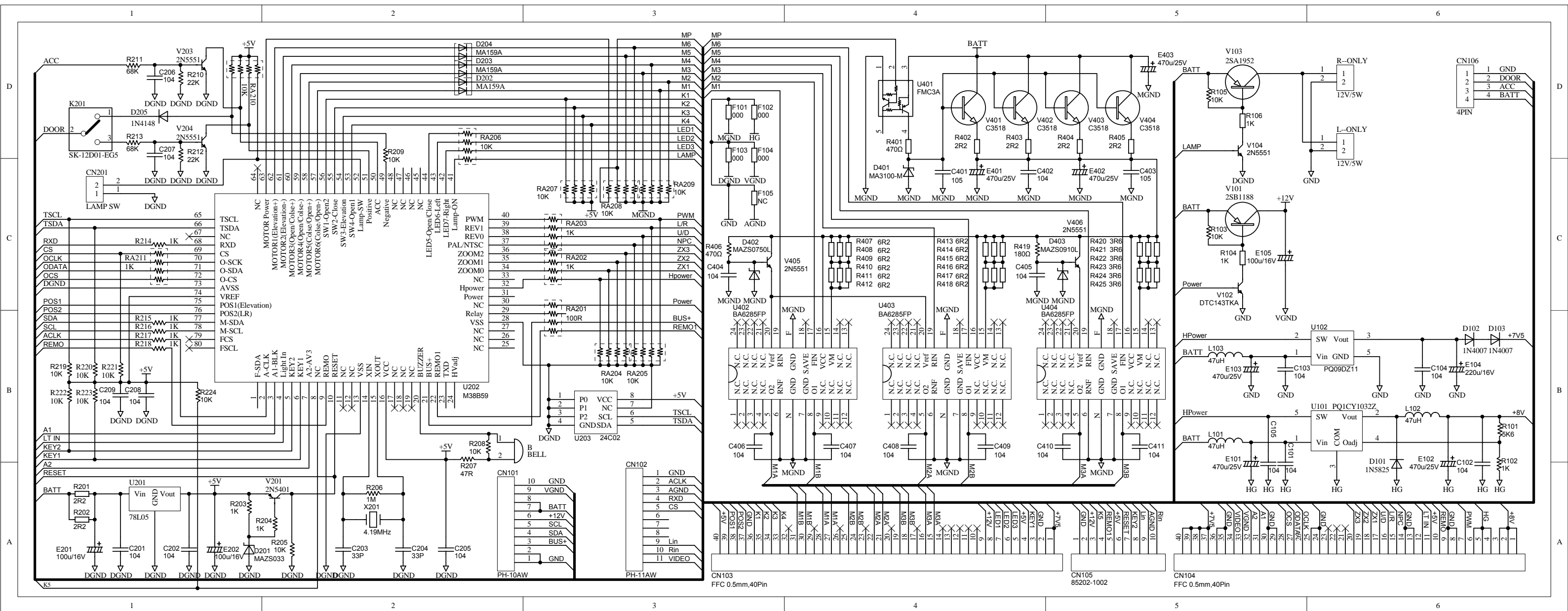

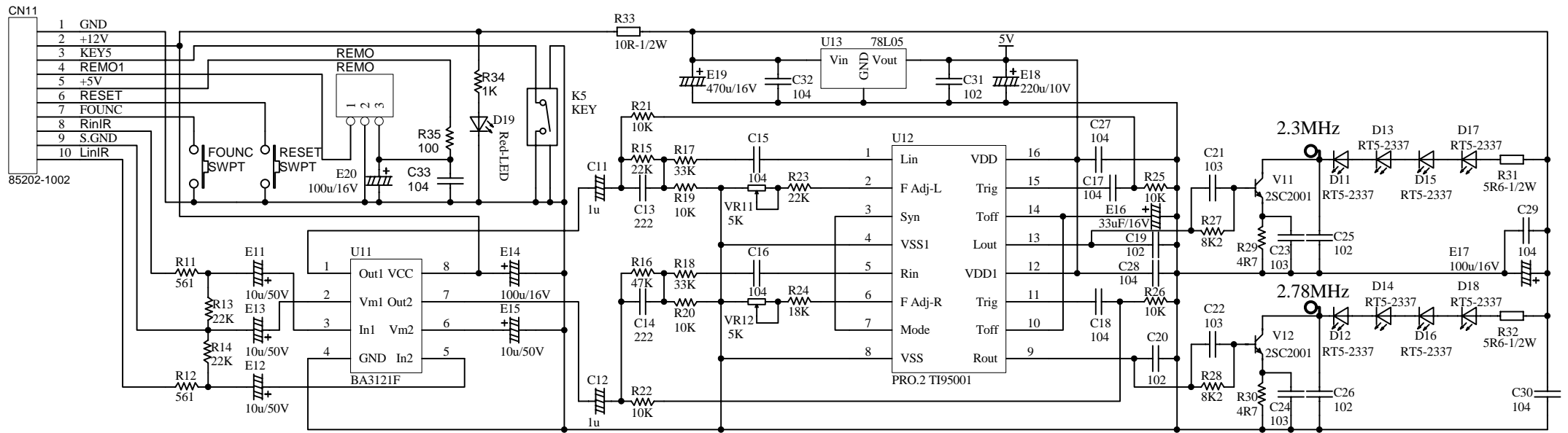

SCHEMATIC DIAGRAM MAIN Board (3/3)

DVM9000 UNIPAC 7CH 304 SCH

	A1	A2
PIC OFF	H	H
RGB INPUT	L	H
VIDEO INPUT	H	L

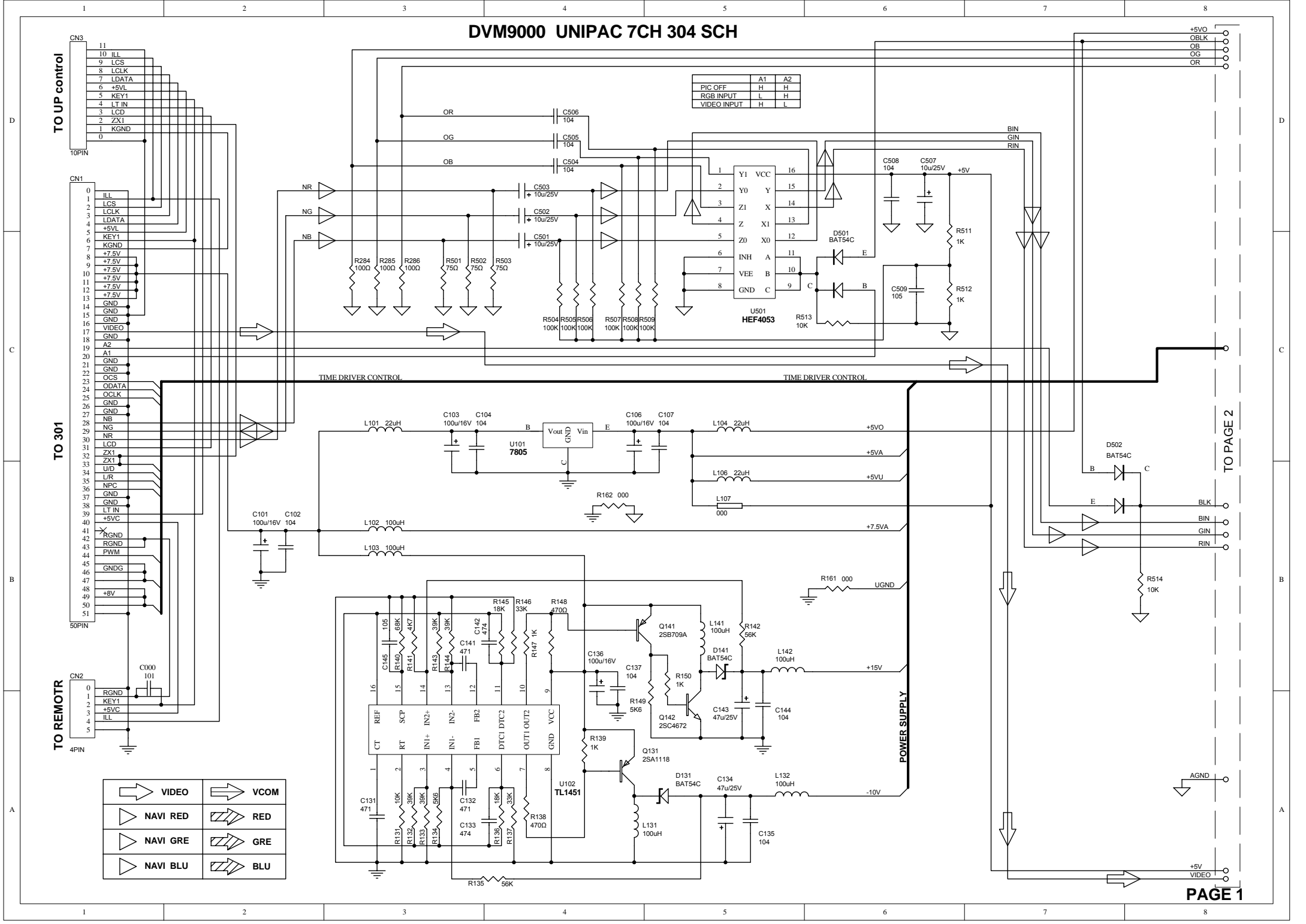

	VIDEO		VCOM
	NAVI RED		RED
	NAVI GRE		GRE
	NAVI BLU		BLU

DVM9000 UNIPAC 7CH 304 SCH

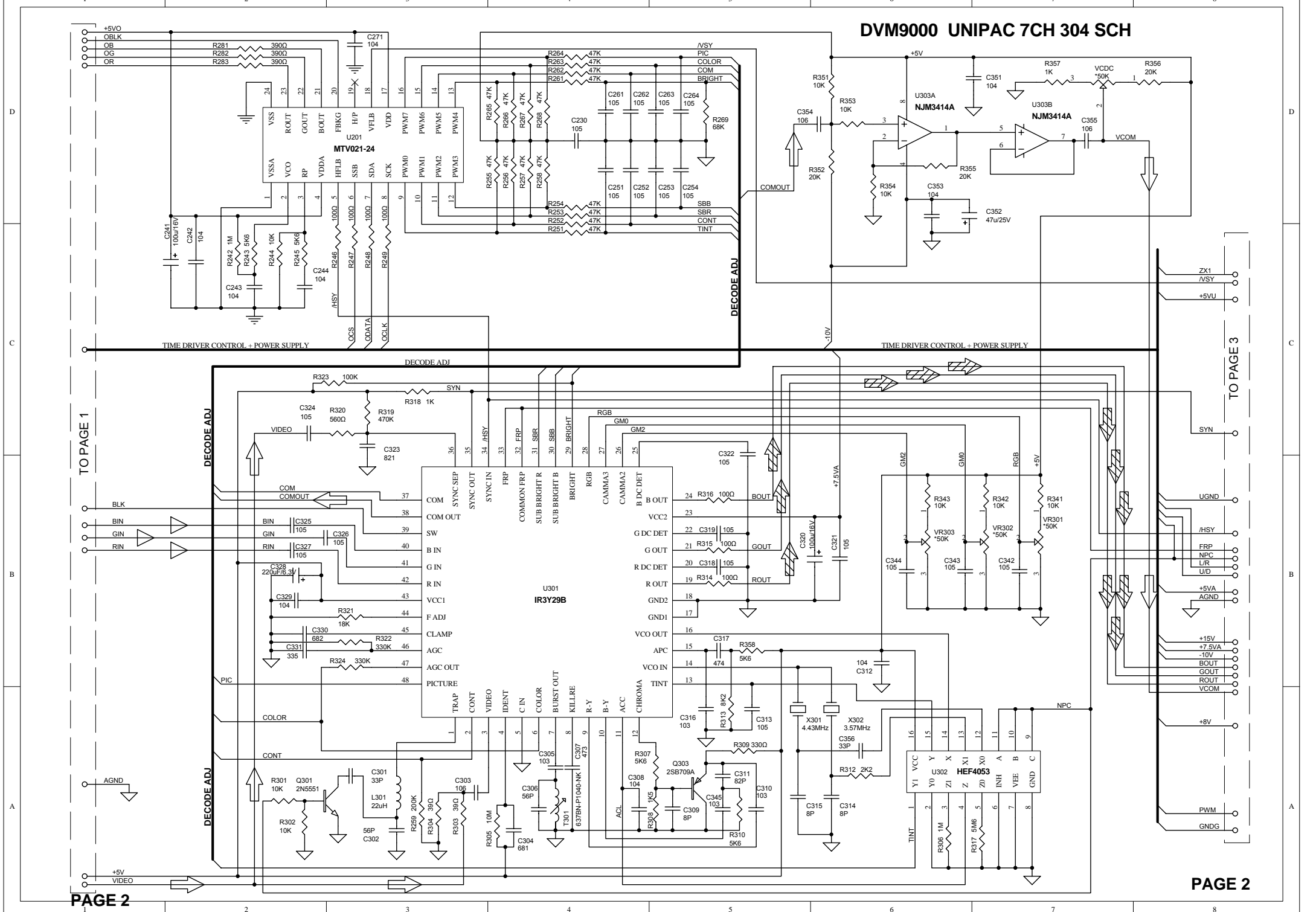

TO PAGE 3

DVM9000 UNIPAC 7CH 304 SCH

